



P/N: CLOSURE40

TopX DOME JOINT CLOSURE 1 IN 4 OUT Max 144F

Description

Optical splice closures are used to distribute, splice, and store the outdoor optical cables which enter and exit from the ends of the closure. There are two connection ways: direct connection and splitting connection. They are applicable to situations such as overhead, man-well of pipeline, embedded situation etc. Compared to terminal box, the closure requires much stricter requirement of seal. Sealing ring and air valve are required for closure, while not necessary for terminal box.

Features

1. The closure casing is made of quality engineering plastics, and of good performance of anti-erosion against acid and alkali salt, anti-aging, as well as smooth appearance and reliable mechanical structure.
2. The mechanical structure is reliable and has the performance of resisting wild environment and intensive climate changes and serious working environment. The protection grade reaches IP68.
3. The closures are applicable to ribbon type optical cable and common optical cable.
4. The splice trays inside the closure are turn-able like booklets, and have adequate curvature radius and space for winding optical fiber to make sure the curvature radius for optical winding 40mm. Each optical cable and fiber can be operated individually.
5. The closure is of small volume, big capacity and convenient maintenance. The elastic rubber seal rings inside the closure are of good sealing and sweat-proof performance.
6. The casing can be opened repeatedly without air leakage. No special tools are required. The operation is easy and simple. The air valve is provided for the closure and used to check the sealing performance.





Accessories

Tag paper: 1 pcs
Sand paper : 1 pcs
Silver paper : 1 pcs
Cleaning tissue: 1 pcs
Insulating tape: 1 pcs
Cable tie: 3mm*10mm 8 pcs
Fiber protective tube: 1 pcs
Heat-shrink sleeve: 1.0mm*3mm*60mm 144 pcs
Heat shrink tubing: 1 bag
Pole accessories: 1 pcs



Dimensions and Capability

Dimensions (D*H)	420mm*205mm
Max Capacity	144 Cores
Number of Cable Entrance/Exit	1:4
Diameter of Cable	4 small round ports(21mm) and 1 large oval port(58mm)

Operation Conditions

Temperature	-40°C~+60°C
Humidity	≤95% (at 40°C)
Air Pressure	70kPa ~106kPa

Technical Specifications

- Seal performance: after the box is sealed, inflate to 100kPa inwards (inflation only apply to the models with the air hole), and then soak it in the water of normal temperature, after 15 minutes of steady observation, there is no bubble to overflow.
- Insulation resistance: the insulation resistance between the metal work piece and the earth is greater than 20kMΩ.
- Pressurization: there is no breakdown or flashover under 15kVdc/1min between the metal work piece and the earth.



- The curvature radius of the fiber 40mm, without extra loss inside the splice tray.
- It can bear the axial tensile strength no less than 1000N.
- Lifetime: 25 years.
- Other performances are all in accordance with the requirement of standard YD/T814-1998.

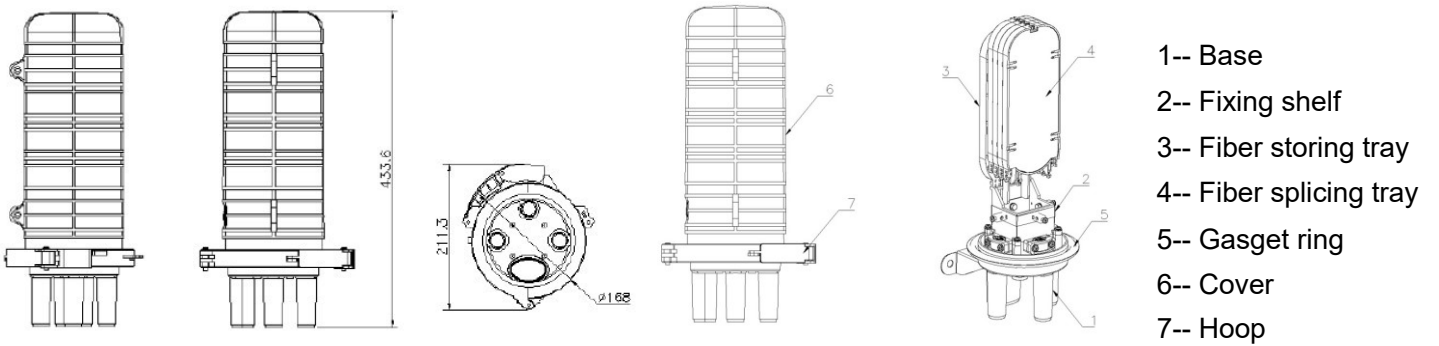

- 1-- Base
- 2-- Fixing shelf
- 3-- Fiber storing tray
- 4-- Fiber splicing tray
- 5-- Gasget ring
- 6-- Cover
- 7-- Hoop

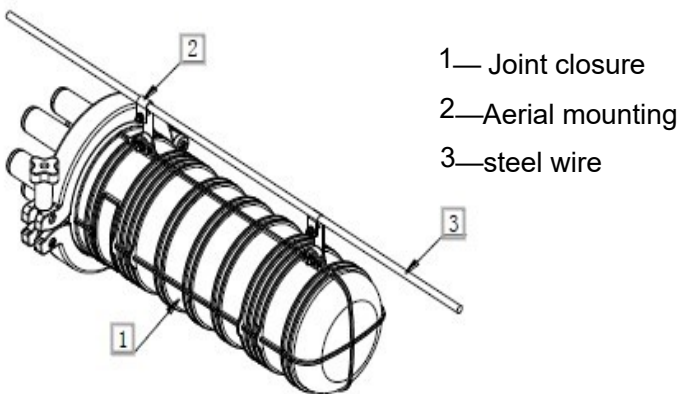

- 1— Joint closure
- 2—Aerial mounting
- 3—steel wire

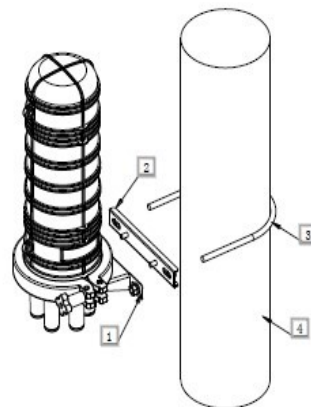

- 1—Fixing plate
- 2—Mounting plate
- 3—U-shaped bolt
- 4—Pole

Aerial mounting

Pole mounting